

YX2265

65V_{IN}, 65V_{OUT}, Synchronous Buck-Boost CC/CV Controller

PRODUCT INTRODUCTION

The YX2265 is a synchronous buck-boost controller suited for driving silicon MOSFET or Gallium Nitride (GaN) power transistors in highly efficient power converters. It supports wide input and output range up to 65V with seamless transitions between buck, buck-boost and boost modes. The YX2265 integrates both high side and low side gate drivers with UVLO protections. It provides programmable inductor peak current limit and output current limit functions with output instant current monitoring capability through ISMON. The CC/CV regulation capability allows it to be fitting in battery charging systems.

It also features external compensation, programmable soft-start to reduce the inrush current during start up. It also supports adjustable dead time control for optimal turn-on/-off of power switches to reduce switching loss for high efficiency. The YX2265 supports ultra-wide switching frequency range from 50KHz up to 3MHz and integrates frequency spread spectrum (FSS) for EMI optimization. Optional external clock synchronization function facilitates the parallel operation. It also features external compensation, programmable soft-start to reduce the inrush current during start up. The YX2265 is available in 32-lead QFN package.

FEATURES

- Wide V_{IN}: 2.7V to 65V, Wide V_{OUT}: 2V to 65V
- Up to 98% Power efficiency
- Ultra-wide switching frequency: 50KHz to 3MHz
- CC/CV regulation capability
- 5V driver voltage for Si FETs or GaN FETs
- Gate driver: 0.6Ω pull-down, 1.2Ω pull-up resistance
- Drive supply rail UVLO protection
- Adjustable dead time control
- Frequency spread spectrum (FSS)
- Integrated high accuracy (±1%) 1.8V VREF
- 32-Lead side-wettable QFN Package

APPLICATIONS

- Buck-Boost DC-DC supplies
- USB 3.1 type C Chargers
- Consumer, Industrial and Automotive
- Solar energy MPPT optimizer

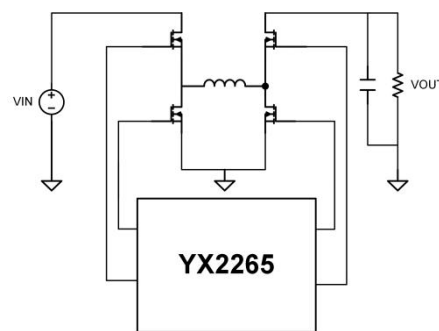

Simplified Circuit Diagram