

YX8180

65V_{IN}, 65V_{OUT} Synchronous Boost GaN LED Driver

PRODUCT INTRODUCTION

The YX8180 is a synchronous boost GaN LED driver suited for driving Gallium Nitride (GaN) power transistors for highly efficient LED application. It supports a wide output range up to 65V with maximum 98% power efficiency. It provides programmable output current limiting and accurate LED current regulation. The LED open and short detection features protect device from external fault condition. The YX8180 integrates both high side and low side gate drivers with UVLO protections for both drive rails, which support both synchronous and non-synchronous boost LED driver. The programmable compensation and soft-start functions provide flexible design. It also supports adjustable dead time control for optimal turn on/off of power switches to reduce switching loss for high efficiency.

The YX8180 supports ultra-wide switching frequency range from 50KHz up to 3MHz and integrates frequency spread spectrum (FSS) and fault reporting. The YX8180 is available in 32-lead QFN package.

FEATURES

- Up to 98% power efficiency
- Wide input and output voltage range up to 65V
- Ultra-wide switching frequency: 50KHz to 3MHz
- 5V driver voltage for Si FETs or GaN FETs
- High LED current accuracy ($\pm 3\%$)
- Support both PWM Dimming (2000:1) and Analog Dimming
- Drive supply rail UVLO protection
- Adjustable dead time control
- Frequency spread spectrum (FSS)
- Integrated high accuracy ($\pm 1\%$) 1.8V VREF
- Open LED and short LED protection
- 32-Lead side-wettable QFN Package

APPLICATIONS

- High power LED drivers
- Vehicle head lights/tail lights
- Consumer, Industrial and Automotive

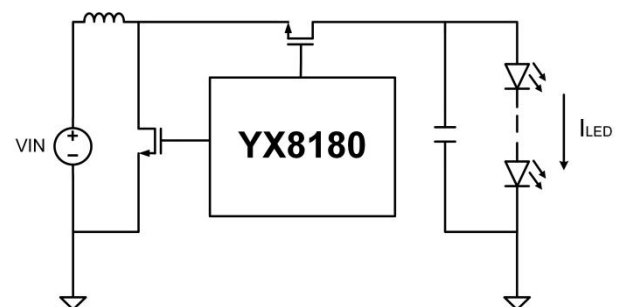

Simplified Circuit Diagram