

YX8280

65V_{IN}, 65V_{OUT}, Synchronous Buck-Boost GaN LED Driver

PRODUCT INTRODUCTION

The YX8280 is a synchronous buck-boost GaN LED driver suited for driving Gallium Nitride (GaN) power transistors in highly efficient DC-DC power converters. It supports a wide input and output ranges up to 65V with seamless transitions between buck, buck-boost and boost mode. It provides programmable input current limiting and accurate LED current regulation. The LED open and short detection features protecting device from external fault condition. It also supports adjustable dead time control for optimal turn on/off of power switches to reduce switching loss for high efficiency.

The YX8280 supports ultra-wide switching frequency range from 50KHz up to 3MHz and integrates frequency spread spectrum (FSS) for EMI optimization. It also features external compensation, programmable soft-start and fault reporting.

FEATURES

- Up to 98% power efficiency
- Wide input and output voltage range up to 65V
- Ultra-wide switching frequency: 50KHz to 3MHz
- 5V driver voltage for Si FETs or GaN FETs
- High LED current accuracy ($\pm 3\%$)
- Support both PWM Dimming (2000:1) and Analog Dimming
- Drive supply rail UVLO protection
- Adjustable dead time control
- Frequency spread spectrum (FSS)
- Integrated high accuracy ($\pm 1\%$) 1.8V VREF
- Open LED and short LED protection
- 32-Lead side-wettable QFN Package

APPLICATIONS

- High power LED drivers
- Vehicle head lights/tail lights
- Consumer, Industrial and Automotive

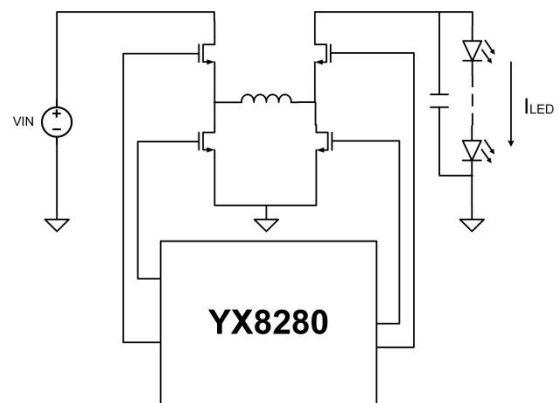

Simplified Circuit Diagram